



# DUOPORT OSA

## Cabinet size

**widths** : 350 / 450 / 550 / 600 mm

**depth min** : 290 mm

## Installation measurements

### heights:

**OSA 1** 500 mm - 700 mm (2 racks)

**OSA 2** 700 mm - 900 mm (3 racks)

## Description

**Fitting** : RAL 9006 silver, clear varnish

**Baskets** : chrome  
RAL 9006 silver, clear varnish

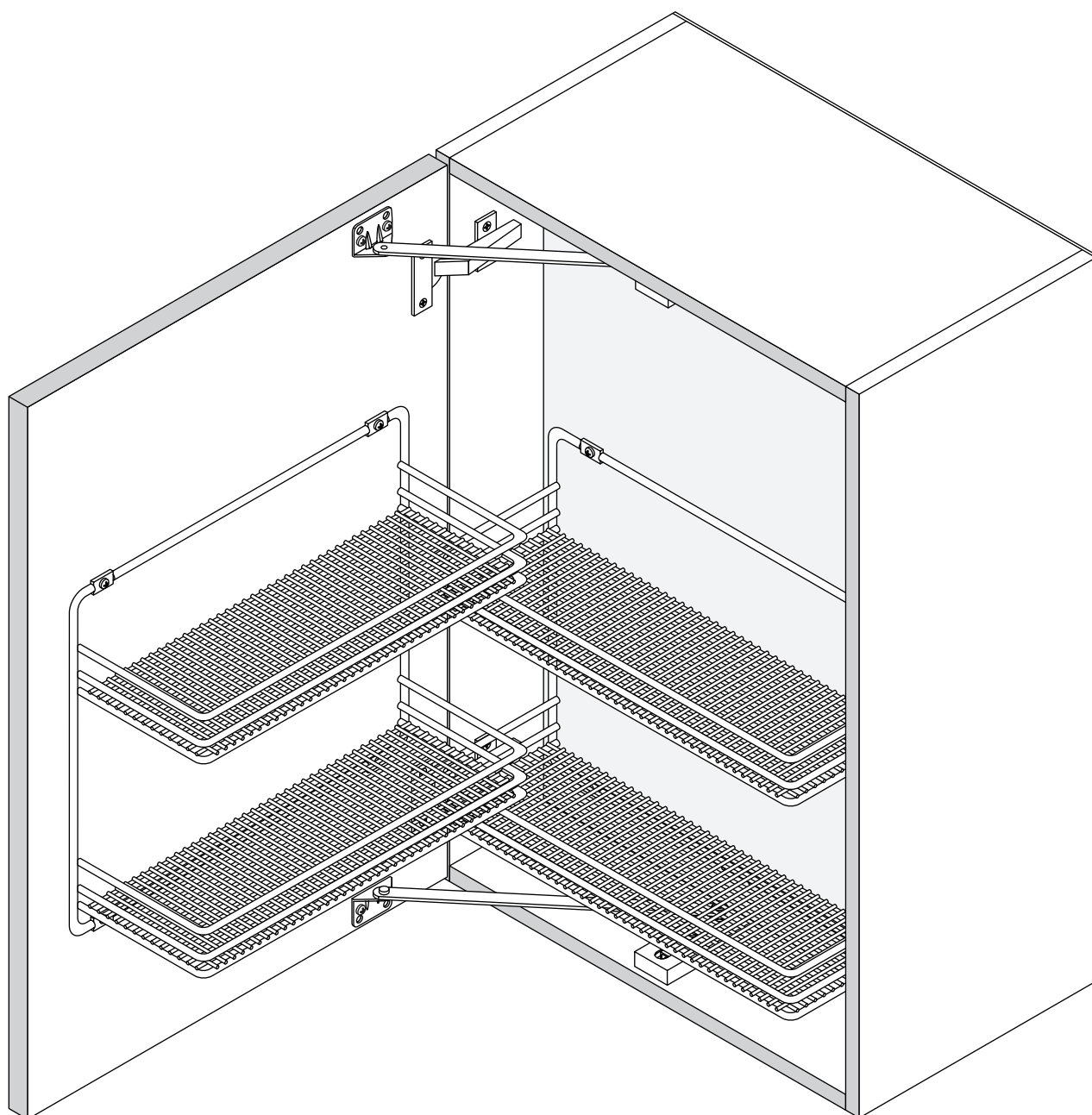



### 1 Assembly

#### Lower guide slide

The guide slide (ball-bearing) is screwed to the floor board 23 mm from the cabinet front edge (to about the middle of the 1st drill hole of the guide slide).

**Fasteners:**

countersunk screws 4.0 x 16

Now place the sleeve spacers (brass) on the threaded studs.

Then snap the plastic cover over it.

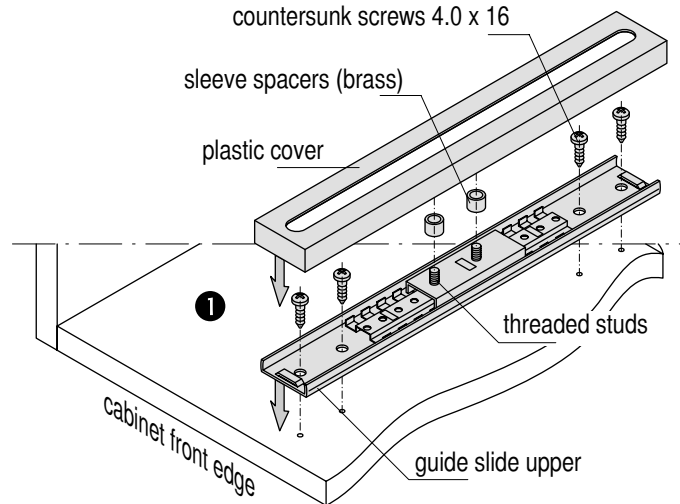

### 2 Assembly

#### Upper guide slide

The guide slide (ball-bearing) is screwed to the ceiling board 23 mm from the cabinet front edge (to about the middle of the 1st drill hole of the guide slide).

**Fasteners:**

countersunk screws 4.0 x 16

Then snap the plastic cover over it.

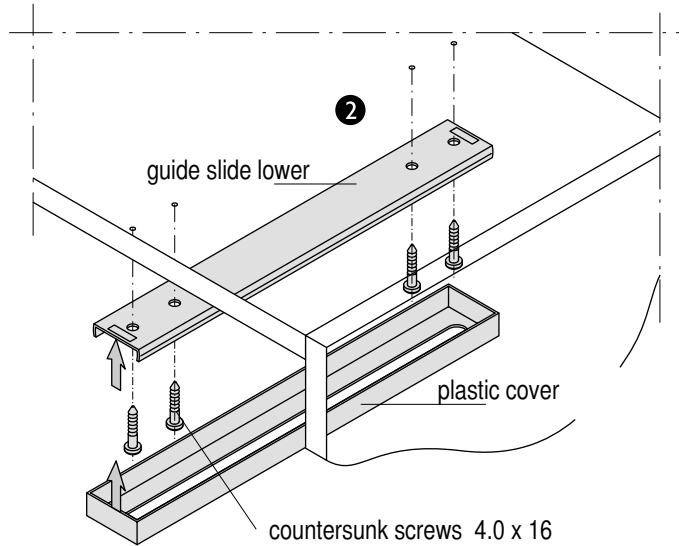

### 3 Assembly

#### Driver "top / bottom"

The supports for the driver are to be placed in such a manner (using 110 degree hinges) that from the cabinet edge hinge to the middle of the first screw hole the measurement X is attained (see diagram "A"). The distance of the cabinet edge "upper" and "lower" door amounts to 17 mm + door strike.

**Fasteners:**

countersunk screws 4.0 x 16

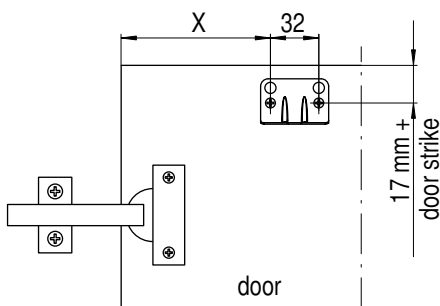
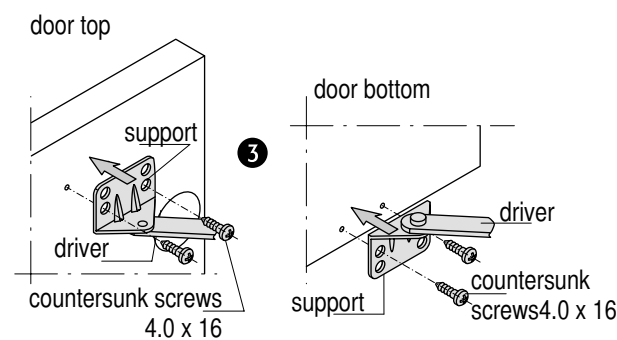

**diagram A**

cabinet 300	X = 59
cabinet 350	X = 49
cabinet 450	X = 45
cabinet 500	X = 42
cabinet 600	X = 42

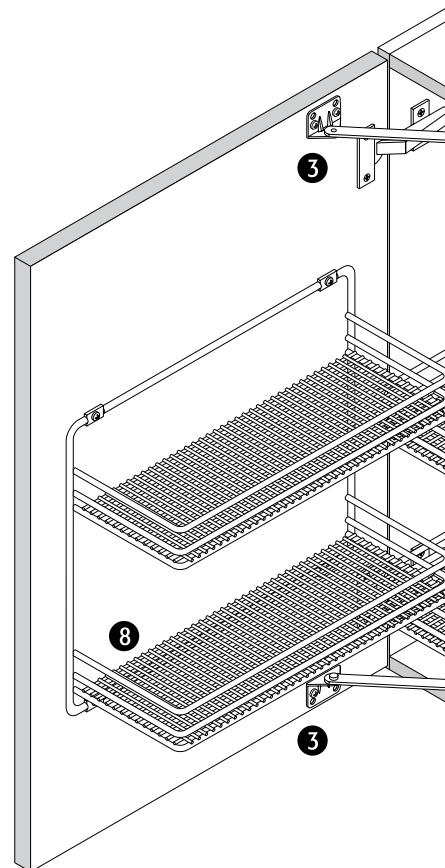

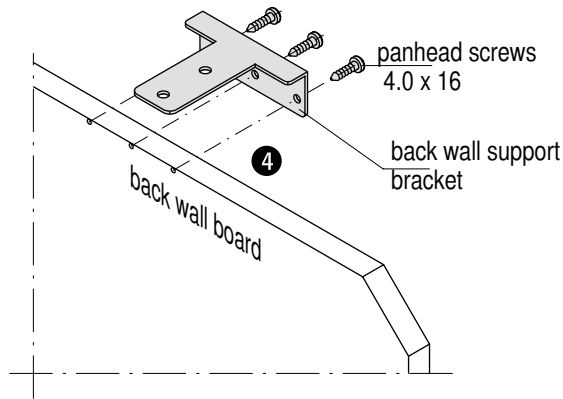
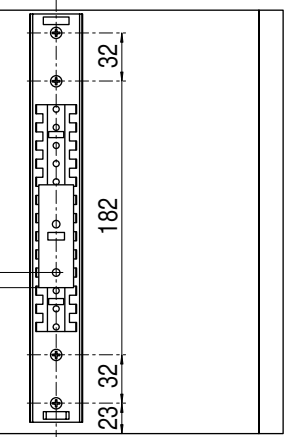

#### 4 Assembly of the back wall support "top / bottom"

The back wall support bracket is to be screwed onto the middle of the backside of the back wall board.

**Fasteners:**  
panhead screws 4.0 x 16

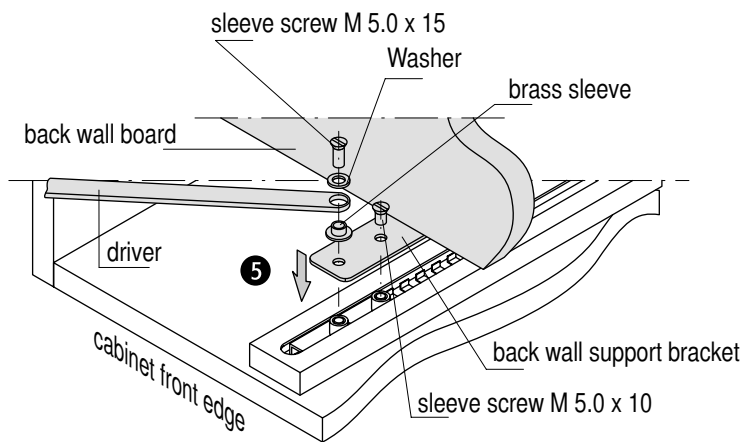

#### 5 Assembly of the "bottom" back wall board

Place the back wall board on the lower guide slide and screw to the back threaded stud using sleeve screw M 5.0 x 10. Then place the driver on the front threaded stud, insert brass sleeve and screw on with sleeve screw M 5.0 x 15 and washer.

**Fasteners:**  
Washer  
Sleeve screw M 5.0 x 10  
Sleeve screw M 5.0 x 15  
Brass sleeve

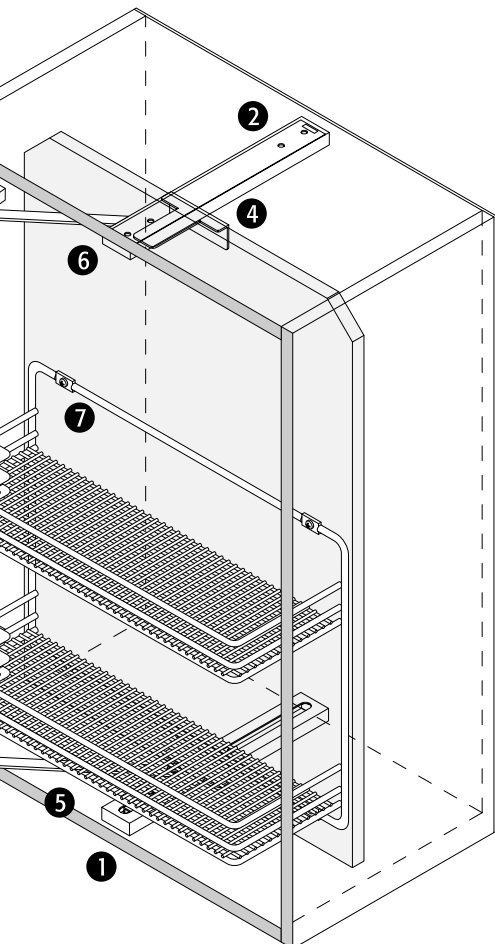

#### 6 Assembly of the "top" back wall board

Insert the back wall board on the upper guide slide and screw to the back threaded stud using sleeve screw M 5.0 x 15. Then place the driver on the front threaded stud, insert brass sleeve and screw on with sleeve screw M 5 x 20 and washer.

**Fasteners:**  
Washer  
Sleeve screw M 5.0 x 10  
Sleeve screw M 5.0 x 20  
Brass sleeve

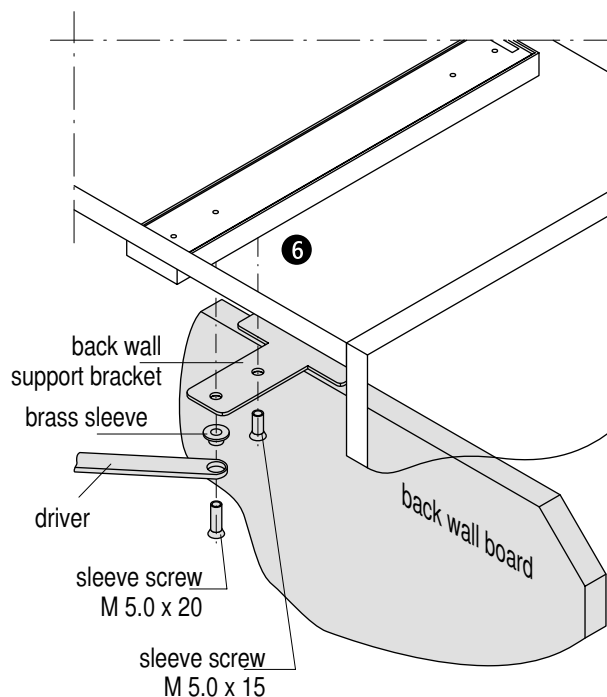

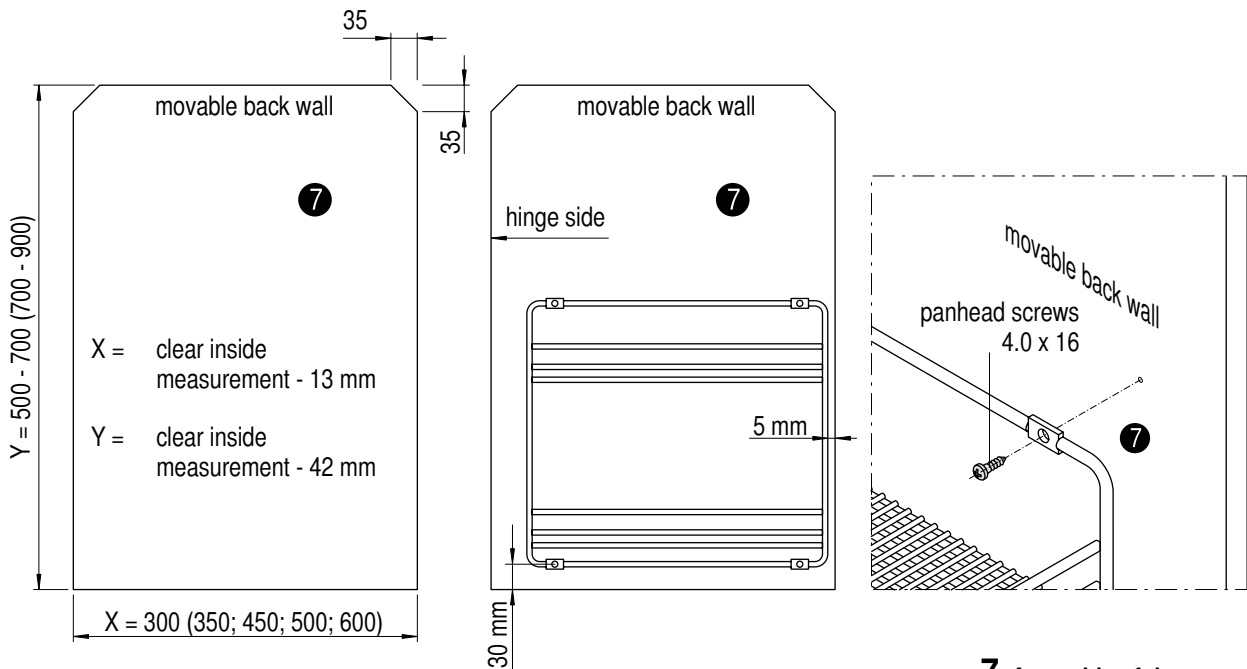

### 7 Assembly of the back wall "rack"

The rack on the back wall is to be screwed on in such a manner that there is a space of 30 mm from the lower edge of the movable back wall to the middle of the first screw hole of the rack. The space between the movable base on the left to the rack should be 5 mm.

**Fasteners:**  
panhead screws 4.0 x 16

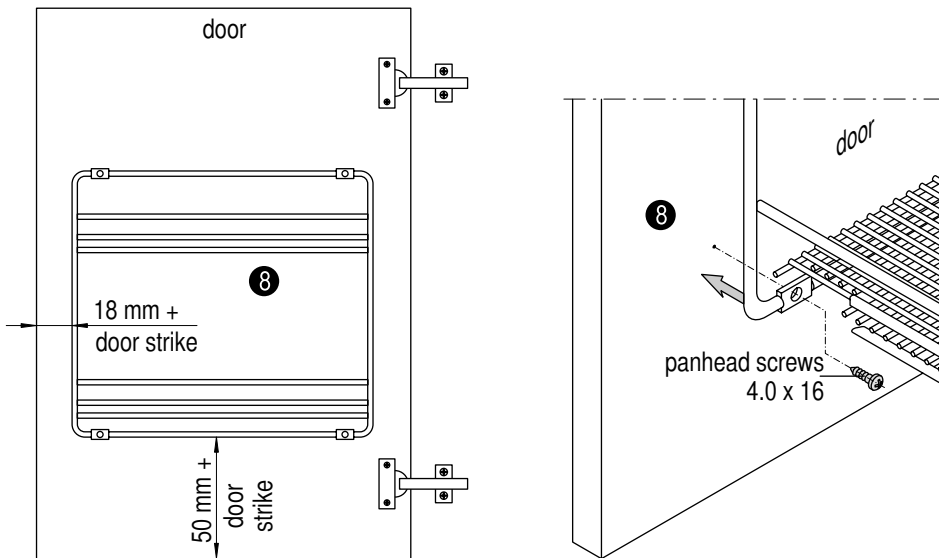

### 8 Assembly of the door "rack"

The rack on the door is to be screwed on in such a manner that there is a space of 18 mm + door stike from door inside (across from the side with the door hinge) and from the door edge on the bottom to the rack lower edge there should be a space of 50 mm + door strike.

**Fasteners:**  
panhead screws 4.0 x 16

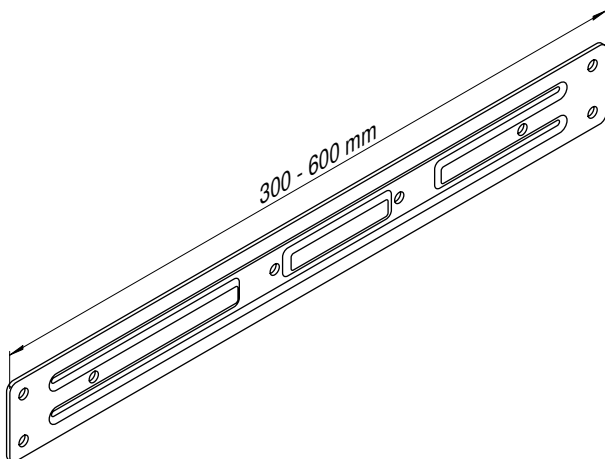

**Note:**  
adapter guides are available for frame doors.

Vauth-Sagel SYSTEMTECHNIK  
GmbH & Co.KG  
Neue Straße 27  
D-33034 Brakel-Erkeln  
Tel. +49-52 72/6 01-01  
Fax. +49-52 72/6 01-193  
www.vauth-sagel.de  
e-mail: VS@Vauth-Sagel.de